

mimosa

B5-Lite

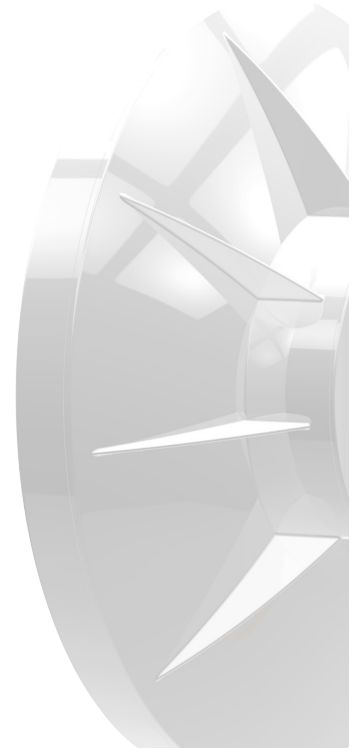

Fast. Affordable. Easy.

Switch to the award-winning Mimosa B5-Lite, the easiest, fastest and most affordable wireless bridge kit on the market. This backhaul radio is ideal for connecting large properties, co-located office buildings, hospital buildings or campuses. No fiber in your future? No problem - the B5-Lite is a great short range fiber-digging alternative.

The B5-Lite is a fantastic addition to any network. Make the change today and discover blazing backhaul.

Superior Performance

Our speeds will blow you away. With up to 750 Mbps and under 1 ms of latency, high performance has never been this affordable.

Monitor with Ease

Assessing link health and identifying potential problems is easy. Links are instantly monitored by our Mimosa Cloud service with rich data collection and analysis.

Rugged and Affordable

Extreme outdoor conditions have nothing on the B5-Lite. The B5-Lite handles huge fluctuations with incredible affordability.

Just Mount and Go

Connect quickly with our complete kit including super compact integrated antennas and wall mounts. Includes optional pole mounting kit.

Technical Specifications

Performance

- **Max Throughput:** 750+ Mbps
- **Low Latency:** Configurable to 5ms+
- **Wireless Protocols:** Auto-TDD/TDMA

Radio

- **MIMO & Modulation:** 2x2:2 MIMO OFDM up to 256 QAM
- **Bandwidth†:** 20/40/80 MHz channels tunable to 5 MHz increments
- **Frequency Range:** 5470-5850 MHz
- **Max Output Power:** 23 dBm
- **Sensitivity (MCS 0):**
 - 87 dBm @ 80 MHz
 - 90 dBm @ 40 MHz
 - 93 dBm @ 20 MHz

Antenna

- **Beamwidth (3dB):** 14° (azimuth and elevation)
- **Cross-Polar Isolation:** >20 dB
- **Polarization:** Dual 45° slant polarization

Power

- **Max Power Consumption:** 15W
- **System Power Method:** 802.3at compliant
- **PoE Power Supply:** Passive POE compliant, 48-56 V Power over Ethernet supply with IEC61000-4-5 surge protection

Physical

- **Dimensions:**
 - Width: 153.31 mm (6.04")
 - Diameter: 260.33 mm (10.25")
- **Weight:** 0.72 Kg (1lbs 9oz)
- **Enclosure Characteristics:** Outdoor UV stabilized plastic
- **Wind Survivability:** 200 km/h (125 mph)
- **Wind Loading:** 39 kg @ 160 km/h

(86 lbs @ 100 mph)

- **Mounting:** Single pole strap feed point integrated into plastic back plate with integrated curvature for contact with mounting poles. Azimuth and Elevation adjustability only provided via J-mount elevation adjustment and hose clamp loosened rotation on the pole.

Environmental

- **Outdoor Ingress Protection Rating:** IP55
- **Operating Temperature:** -40°C to +55°C (-40°F to 131°F)
- **Operating Humidity:** 5 to 100% condensing
- **Operating Altitude:** 4420 m (14500') maximum
- **Shock & Vibration:** ETS 300-019-2-4 class 4M5

Features

- **Gigabit Ethernet:** 10/100/1000-BASE-T
- **Management Services:** Mimosa cloud monitoring and management SNMPv2 & Syslog legacy monitoring HTTPS HTML 5 based Web UI
- **Smart Spectrum Management:** Active scan monitors/logs ongoing RF interference across channels (no service impact) Dynamic auto-optimization of channel and bandwidth use
- **Security:** WPA2 + Mimosa 802.1x Client
- **QoS:** Supports 4 pre-configured QoS levels

Regulatory + Compliance

- **Approvals:** FCC Part 15.407 and Part 90Y, IC RS210, CE, ETSI 301 893/302 502
- **RoHS Compliance:** Yes
- **Safety:** UL/EC/EN/ 60950-1 + CSA-22.2

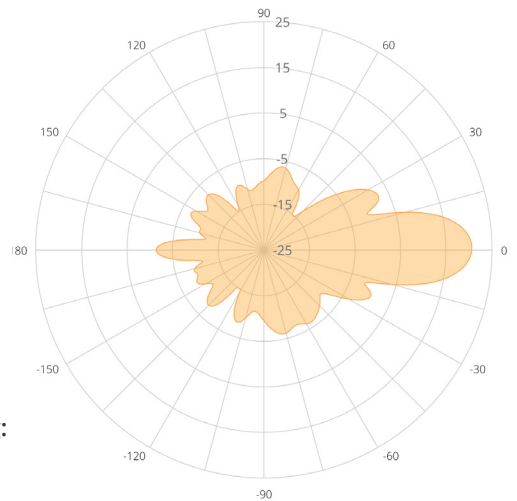

B5-Lite Azimuth Polar Plot

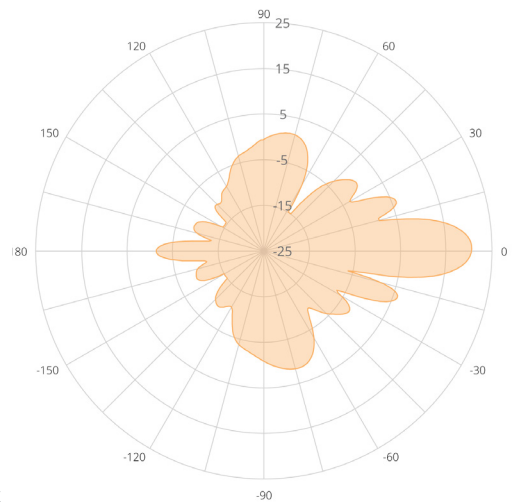

B5-Lite Elevation Polar Plot

Mimosa Networks, Inc. • www.mimosa.co • @gomimosa

©2016 Mimosa Networks, Inc. All rights reserved. The Mimosa logo is a registered trademark of Mimosa Networks, Inc. in the United States. All other company names may be trade names or trademarks of their respective owners. 705-00004 RevB 4/16



Planet Communications Asia PLC.

157 Soi Ramindra 34, Ramindra Rd., Tarang, Bangkhen, Bangkok 10230
Tel: +66 2 792 2400 | Fax: +66 2 792 2499, +66 2 943 5771 | E-mail: sales@planetcomm.com

mimosa



PlanetComm: